

NCHRP

NATIONAL
COOPERATIVE
HIGHWAY
RESEARCH
PROGRAM

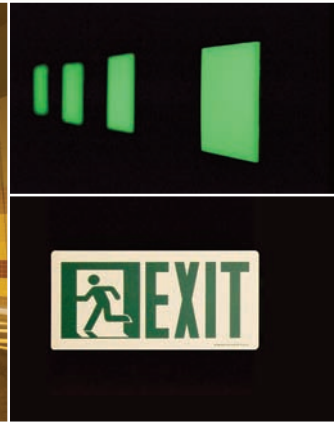

Proposed Guidelines for Emergency Exit Signs and Marking Systems for Highway Tunnels

TRB TRANSPORTATION RESEARCH BOARD

The National Academies of

SCIENCES • ENGINEERING • MEDICINE

Contents

Introduction	1
Highway Tunnel Emergency Hazards	1
Purpose of the Guide	2
Recommended Guidelines for Emergency Exit Messages, Signs, and Markings	3
Emergency Exit Signs	3
Exit Door Lighting and Markings	5
Exit Path Markings	6
Emergency Messages	7
Installation and Maintenance Considerations	9
Considerations for Emergency Response Procedures and Training	10
Considerations for Public Outreach and Education	10
Public Education Prior to an Incident	10
Communication During an Incident	11
Appendix: NCHRP Project 20-59(47) Summary and Outcomes	12
Evacuation Messages	12
Comprehension of Signs and Markings	14
Sign Luminance, Contrast, and Visibility Distance	16
Guideline References	17



Introduction

Highway Tunnel Emergency Hazards

Vehicle crashes, fires, hazardous waste spills, or terrorist activities are particularly hazardous when they occur inside tunnels. The enclosed environment of a highway tunnel can concentrate heat, smoke, or other toxic gases resulting from an incident. The limited right-of-way means that even a partially blocked lane can potentially trap vehicles and hinder access for emergency responders. As a result, tunnel users may need to evacuate themselves on foot via emergency exits.

Studies of past tunnel emergencies have found that tunnel users often do not act independently to evacuate themselves on foot, instead choosing to remain in or near their vehicles. Some reasons for making the potentially fatal decision not to evacuate are

- the lack of awareness of an unfolding hazard,
- uncertainty about the appropriate course of action,
- reluctance to leave the perceived safety of the vehicle, and
- reluctance to abandon property.

During an emergency, people have a tendency to wait for information or instruction rather than seek it out. If and when people do decide to exit a tunnel in the face of a recognized danger, they have a tendency to try to reach the main tunnel portal, rather than emergency exits for pedestrians, which may be nearer. In fact, drivers may not be aware of the existence of emergency exits or cross-passageways, and therefore may not recognize the purpose of exit doors along the tunnel wall. Additionally, people tend to overestimate the amount of

time they have to evacuate during a fire—a potentially fatal mistake since fire and smoke can spread quickly in a tunnel fire.^{1,2}

In the absence of emergency responders to give directions, in-tunnel signs, marking systems, lighting, and/or audible signals must provide direction to tunnel users. Both the need to evacuate and the location of the nearest emergency exits must be clearly communicated.

Purpose of the Guide

In recognition of the particular hazards of emergencies within highway tunnels, standards have been developed and implemented in several countries, particularly in Europe, to facilitate emergency evacuations from highway tunnels. These include standards for signage, lighting, and marking emergency exit doors and the paths leading to those doors. The purpose of this guide is to provide recommendations for emergency exit signs and markings for highway tunnels in the United States. This will expand on the guidance provided by the National Fire Protection Association’s (NFPA) guidelines, NFPA 502, NFPA 72, NFPA 101, and NFPA 170, and assist tunnel operators in the United States as they address various aspects of tunnel safety.

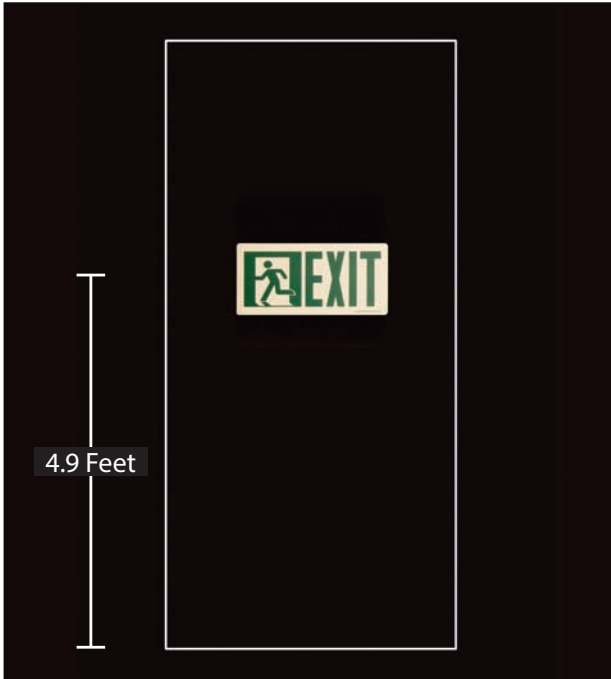

Figure 1. Exit Door Sign Format

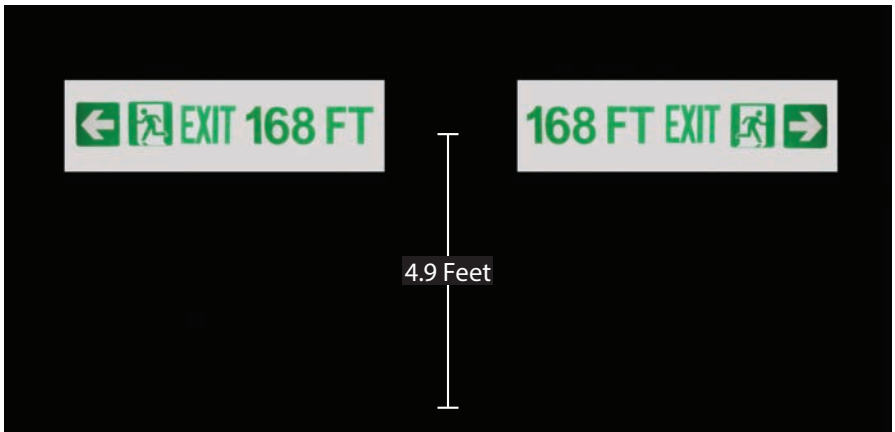

Figure 2. Sample Exit Directional Sign Formats

Recommended Guidelines for Emergency Exit Messages, Signs, and Markings

The following recommendations are based on the results of the human factors studies conducted during NCHRP Project 20-59(47) (see Appendix for a summary); input from experts on the project’s advisory panel and tunnel operators and emergency responders interviewed during the study; and prior research and standards from the United States and elsewhere (as referenced in the following sections).

Emergency Exit Signs

Use reflective, photoluminescent, or lighted signs on tunnel side walls to indicate the direction and distance to the two nearest emergency exits.³ Additional recommendations for exit signs, based on other existing standards and the results of NCHRP Project 20-59 (47), are summarized in this section.

Emergency Exit Door and Directional Sign Formats. Use the “running man” symbol,^{4,5} in combination with the word “EXIT,” for emergency exit door and directional signs as shown in figures 1 and 2. The sign colors should be green text and symbols on a white background.

Directional signs should include the “running man” symbol and EXIT text, with the addition of a tailed directional arrow and the distance to the nearest exit in feet.

Emergency Exit Door Sign Location. Place on the exit door if possible, or on the tunnel wall immediately to the right or left of the door, preferably with the midpoint of the sign no higher than 1.5 meters (4.9 feet) above the floor.

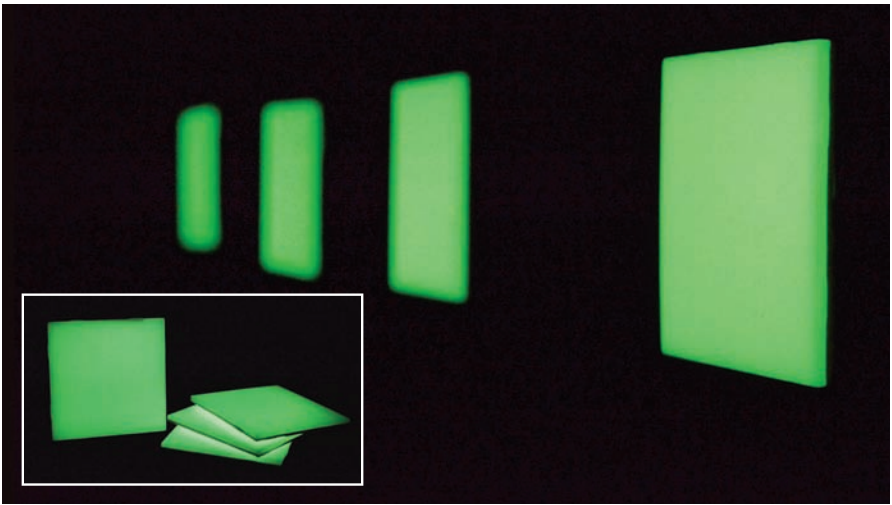

Figure 3. Sample of Photoluminescent Exit Path Markings

Emergency Exit Directional Sign Location. Place signs every 25 meters (82 feet) or less along the tunnel wall.³ If exits are located in two directions relative to the location of the sign, two signs should be placed side by side to indicate the directions and respective distances to the two exits. These signs leave judgment to the evacuee as to what direction they should evacuate since there are too many potential scenarios that may affect exit direction. Most common, however, is a uni-directional tunnel where the fire is presumed to be in advance of the trapped vehicle. In this scenario ventilation should be moving the smoke in that same direction; therefore, pedestrians should exit toward the rear of the tunnel and uni-directional signs may be appropriate.

Exit Sign Size. The minimum text size for exit signs or directional signs should be 6 inches (15 cm).⁶ The “running man” symbols should be at least 6 inches (15 cm) tall, with larger symbols encouraged where possible.

Sign Luminance. Minimum luminance levels for emergency exit signs and markings are as follows:

- Externally illuminated signs – not less than 54 lux (5 foot-candles)³
- Internally illuminated signs – not less than 8.6 candela/m² (2.5 foot-lamberts)³

Targeted luminance levels for photoluminescent signs can depend in part on the brightness and duration of available ambient light to charge them. If photoluminescent signs are used for emergency exits or path indicators, it is recommended that they be selected in consultation with a manufacturer, taking expected ambient light levels into consideration.

- Photoluminescent signs – not less than
 - 30 mcd/m², 10 minutes after activating illumination is removed;
 - 5 mcd/m², 90 minutes after activating illumination is removed.⁷

Exit Door Lighting and Markings

Recommendations for lighting exit doors in tunnels are provided by the International Commission on Illumination (CIE) 193-2010 *Emergency Lighting in Road Tunnels*, section 2.3.2. These include the recommendations summarized in this section.

Illumination of Exit Doors. Illuminate a 2-meter (6.5 ft) area surrounding and including each exit door at a level that is 3 to 5 times brighter than the average illumination along that section of the tunnel walls (measurable with a luminance meter).⁸

Emergency Exit Marking Lights. Surround the exit door with strobe lights, activated only in the event of an emergency. Use white or clear strobe lights (at a flash rate range of 1-2 Hz) to signal exits/evacuation. This is a requirement of NFPA 72, which takes precedence in the United States.⁹

CIE 193-2010 recommends green emergency markers flashing at a rate of between 1 and 2 Hz, at minimum luminous intensity of 150 cd in all directions.⁸ Further research may be warranted to compare the visibility of white/clear versus green strobe lights in smoke.

Audible Beacons. An audible beacon may be beneficial as an optional supplementary marker to identify emergency exit doors, in addition to doorway lighting and signage. Recommendations and considerations for the use of audible doorway beacons, if used, are as follows:

- Auditory beacons may be used to supplement (not replace) illuminated exit door lighting.
- When used, auditory beacons should only contain a single message, such as

Emerging Technology

Dynamic exit direction signs using flashing green arrows to indicate an exit path and flashing red crosses to indicate a non-viable route were shown to increase the speed of evacuating people from a tunnel in a 2014 study in Greenwich, England. Similarly to dynamic pathway lighting, signs like these may soon be an option for improving pedestrian guidance during a tunnel emergency.¹¹

Emerging Technology

Audible beacons using synchronized longitudinal sound are one emerging technology that may improve speech intelligibility. This technology has been selected for use in several highway tunnels in Germany.¹⁰

“exit here” or “refuge shelter” and may be in more than one language in addition to English.

- Audible signals should comply with the requirements of NFPA 72, Sections 18.4.1 and 18.4.3 (for non-voice signals) and 18.4.10 (for voice messages).⁹ Because of site-specific conditions, a noise study should be conducted by an acoustical engineer to determine viable options.
- The primary benefit of an audible exit door beacon will be realized in the area close to the door. The decibel level used for the beacon should be calibrated to be audible to listeners within a relatively short radius of the door itself (e.g., approximately 10 meters or 33 feet, or the width of the tunnel bore).

Exit Path Markings

Markings to designate pathways to exits can provide supplemental visual guidance and confirm information for pedestrians. In poor visual conditions, such as in the presence of smoke, pathway markings may be especially helpful by providing visual connections between exit sign locations.

Exit Path Marking Formats. Exit path markings can be static or dynamic. The following are recommended exit path marking formats:

- If feasible, path markers should indicate a direction to an exit door. This may be accomplished with a dynamic light array that lights sequentially to indicate a direction. The appropriate direction could be identified and modified remotely at a traffic operations center, if camera coverage provides adequate information for the operator to make such a decision.
- If directional/sequential light-emitting diodes (LED) arrays are not a feasible option, LED lights that can be activated to flash in unison during emergency situations seem to be slightly more effective than steady-state lights for indicating an emergency exit path. The flash rate of either directional or unison flashes should not exceed 2 Hz to minimize the risk of triggering seizures in individuals with photosensitive epilepsy.
- Path direction to exit doors can also be accomplished with static markers that include a directional arrow.

Emergency Evacuation Message

Primary Information

- Nature of the emergency
- Recommended action
- Evacuation direction (if applicable)

Supplementary Information

- Person/entity making announcement
- Supplementary actions and explanation
- Description of exit paths and doors

Location of Exit Path Markings. Place pathway markings no more than 1 meter (3 feet) above the pathway floor. In the event of a build-up of smoke in the tunnel, the low placement may be more visible if pedestrians drop to a crawl or crouch to avoid the smoke layer.⁸

If the pedestrian path is elevated above the vehicle lanes or otherwise visually separated from the vehicle lanes, it may be helpful to mark transitions/access points between the vehicle lanes and the pedestrian path to identify the path and a potential trip hazard.

Spacing of Exit Path Lights. CIE 193:2010 recommends spacing of no more than 10 meters (33 feet) for pathway marker lights.⁸

Spacing of Photoluminescent Exit Path Markers. Based on the visibility distances observed during this NCHRP study during smoky conditions, the maximum recommended spacing for Photoluminescent (PL) path markers (see figure 3) is 3 meters (10 feet).

Emergency Messages

In the case of an emergency that requires drivers to evacuate the tunnel on foot, an emergency message is especially important for encouraging the evacuation. In the event of an in-tunnel emergency or disruptive incident, broadcast a message to drivers if possible, visually (possibly through a dynamic message sign) and/or audibly.

Emerging Technology

Future developments in Connected Vehicle and other wireless technologies may provide new options for delivering auditory messages to drivers within a highway tunnel facility.

Recommendations regarding the content and delivery of emergency messages within highway tunnels are summarized below.

Message Content. The message should contain, at minimum, the following pieces of information:

- A brief statement about the nature of the emergency, e.g., “fire in tunnel” or “vehicle fire ahead.”
- Direct instructions about the action to take, e.g., “walk to exits” or “leave vehicles, walk to exits” if evacuation on foot is warranted. Specify an evacuation direction (e.g., “evacuate the way you came in”) if applicable.



Figure 4. Evacuation Messages

If slightly longer messages are possible, given the medium used, it may be beneficial to include a small amount of supplementary information. Supplementary information might include:

- The name of the person or entity making the announcement, e.g., the tunnel operator or the fire department.
- Reasons for any supplemental actions that are requested. An example request and explanation would be: "Please leave the vehicle key in the ignition if possible so that the vehicle may be moved by emergency personnel."
- Brief instructions about where to walk and/or a description of what exit doors look like.

Dynamic Message Signs (DMS). The 2009 edition of *The Manual on Uniform Traffic Control Devices* limits the length of messages on DMS to two sign phases with no more than three lines of text per phase; furthermore, each of the two phases must be understandable as a stand-alone message, regardless of the order in which the phases are read.¹² A single-line ceiling-mounted DMS may permit only two message components, ideally a brief statement about the nature of the emergency (e.g. "fire in tunnel") and an action directive (e.g., "walk to exits") (see figure 4). Multiple-line DMS will permit somewhat longer messages; however, further research may be warranted to determine if more than two DMS phases are appropriate and beneficial if traffic is stopped rather than moving.

Auditory Messages. An auditory announcement is one option for providing an emergency and/or evacuation message to tunnel drivers. Audio announcements are far more difficult to accomplish in a tunnel than in a building. A potential advantage to an auditory message is greater length and therefore the opportunity to provide more detail than might be possible via DMS. However,

if auditory messages are delivered via speakers inside a tunnel, their use must take into account the challenging acoustics within a tunnel environment.

- *Loudspeakers/Audible Beacons.* Considerations should include the type of audio speaker selected and the particular acoustic conditions in which it will operate. Audio messaging should comply with the requirements of NFPA 72, Sections 18.4.1 and 18.4.3 (for non-voice signals) and 18.4.10 (for voice messages).⁹
- *Radio override.* Auditory messages may be delivered via an override system within the tunnel that broadcasts messages to a vehicle's radio via AM and/or FM frequency. Radio override depends on drivers having vehicle radios on and tuned to appropriate frequencies, which is becoming less common with increased use of satellite radio and smartphone apps. A real-time announcement to turn vehicle radios on can be delivered via DMS, or a static sign at the tunnel entrance can recommend that drivers keep radios on while inside the tunnel. Another technological challenge is potential spillover of a radio override signal to adjacent tunnel bores.
- *Wireless emergency alerts.* Wireless emergency alerts (WEAs) may be used by eligible local government agencies to send emergency alerts over cell phones or in-vehicle radios via participating radio stations. The alerts should be 90 characters or less for cell phones. The alerts should state what the emergency is and the required action. In jurisdictions that prohibit the use of hand-held mobile devices while driving, WEAs may be less effective as a means of notification for highway tunnel emergencies.¹³

Installation and Maintenance Considerations

Install only signs and markings that are warranted for outdoor, wet locations. Exit sign materials suitable for tunnel environments include aluminum and materials with special protective coatings. In cold weather climates, signs/markings should withstand freeze/thaw as temperatures fluctuate.

Consider tunnel washing methods when selecting technologies and materials: Will the signs/markings used need to withstand pressure washing only, or will they need to also resist the scrubbing action of rotating brushes that may be common with tunnel washing? If devices are utilized that are not resistant to water and cleaning agents, ensure they are removable and can be easily detached from tunnel walls prior to cleanings.

Selection of sign attachment hardware should consider the effects of dissimilar metals, to avoid rapid corrosion of the support frame or anchors.

Considerations for Emergency Response Procedures and Training

Tunnel monitoring capabilities and the level of automation of operating systems can help guide decisions and procedures involving emergency exit signs and markings.

If any emergency exit signs, path markings, and/or exit door markings/beacons are dynamic systems or include dynamic elements, activating them may be part of an operator's emergency task list, or may be programmed as part of an automated or partially automated emergency response system. For example, a tunnel evacuation sequence may include activation of signs with pre-determined messages followed by activation of doorway strobe lights.

Inter-agency coordination (e.g., between tunnel operations and local fire/police) is critical to incident response and should be a part of pre-planning for tunnel incidents.

Advances in video, such as the use of cameras operating in both normal and thermal modes, allow tunnel operators to not only see through smoke but to also be able to view smoke. If this level of monitoring is available, control center personnel can then determine appropriate exhaust and supply air flows in the event of a fire. Activation modes for dynamic emergency signs and markings should take these air flow directions into account, as well as the location of the incident itself, in order to direct evacuees away from smoke, fumes, and other hazards.

Planned exercises and training are vital to prevent a minor incident becoming major or a major event causing further injury or deaths, such as an event where motorists are trapped in a tunnel fire. Where possible, training should involve "hands-on" (real or simulated) execution of emergency procedures and communications to supplement verbal and/or written instruction.

Considerations for Public Outreach and Education

Because emergency situations in highway tunnels are so infrequent, drivers are unlikely to know how to react if one occurs. Communication with drivers prior to and during incidents may help to reduce frustration and uncertainty and to encourage safer behaviors.

Public Education Prior to an Incident

Drivers tend to see traffic incidents as an inconvenience, and in the case of queued traffic in a tunnel, motorists may not know what the incident is unless they are fairly close to it. Aggressive driving increases during the onset of an inci-



dent, as some drivers try to quickly pass the incident site; if all lanes are blocked, motorists may exit their vehicles but remain in the traffic lanes, increasing the potential for further injury.

Public service announcements (PSAs) and/or other public outreach materials may be useful for educating drivers about safe behaviors associated with driving in highway tunnels. PSAs could include information about tunnel incident procedures and tunnel emergency exits, such as cross-passageways and refuge areas as applicable.

Communication During an Incident

Once an incident has occurred, communicating with motorists who may be approaching the tunnel and the incident site provides them with a chance to divert and helps to mitigate the build-up of a traffic queue upstream of the incident site.

- At or near the tunnel entrance, tunnel operators and/or emergency responders may be needed to prevent additional traffic from entering the tunnel. Emergency responders may be needed to access, communicate with, and evacuate motorists who are already trapped close to the incident and unable to self-rescue.
- Roadway DMS, online messaging, and social media are some of the ways for local transportation agencies and transportation management centers to communicate real-time information to roadway users about roadway incidents, including tunnel incidents, and divert traffic away from an incident location.

Appendix: NCHRP Project 20-59(47) Summary and Outcomes

NCHRP Project 20-59(47), “Emergency Exit Signs and Marking Systems for Highway Tunnels,” is a response to a problem statement submitted by the American Association of State Highway and Transportation Officials (AASHTO) T-20 Subcommittee on Tunnels. In this study, completed in 2015, researchers investigated methods to encourage drivers to leave the perceived safety of their vehicles during emergencies and methods to guide those individuals out of highway tunnels. The study’s three primary objectives were as follows:

- To evaluate the effectiveness of emergency messages and their delivery methods (i.e., visual, audible, or both) to encourage drivers to leave their vehicles and evacuate a tunnel on foot.
- To evaluate the effectiveness of sign messages and signing and marking formats to lead people to emergency tunnel exits.
- To evaluate the visibility of different sign and marking materials and technologies for use in highway tunnel environments, particularly, when a tunnel is filled with smoke.

Building on prior research and existing standards for emergency exit signs and markings in European tunnels, the researchers tested selected messages, sign and marking formats, and sign and marking technologies with United States drivers. Testing included expert panel discussion, focus groups, and a simulation of a tunnel emergency involving smoke. The expert panel discussion included tunnel operators and emergency responders, and their responses were used to revise the focus group discussion and tunnel fire simulation and to identify potential maintenance or other technical issues pertaining to signs and markings.

Evacuation Messages

Two focus groups were polled to gain a better understanding of how tunnel users might respond to various tunnel incident scenarios and warnings. Participants were presented with pictures, video, and audio clips pertaining to a hypothetical emergency involving fire inside a highway tunnel. The researchers questioned the participants about how they might react to similar situations and to various types of messages about an emergency. The results of the focus group discussions included the following:

- Uncertainty about what is happening might lead to a delayed or incorrect response, so it is important to relay to tunnel occupants details about the emergency or at least instruct the drivers to evacuate the tunnel.



- The messages that participants found most useful included a brief statement about the emergency, followed by a direct action statement. Examples of this type of message, displayed on an electronic message sign, included “Emergency – walk to exits” and “Fire in tunnel – walk to exits.” Audio messages including the same information elements were also considered effective.

The effects of evacuation messages on driver decisions were tested with a different group of participants in the tunnel simulation. Each simulation participant experienced a simulated vehicle trip through a highway tunnel via a projected video. Approximately 90 seconds into the trip, the vehicle’s progress was stopped by a traffic jam inside the tunnel, which was then followed by the appearance of smoke and the sounds of stopped traffic and tunnel emergency ventilation. One-third of participants received only these visual and auditory cues to the situation, one-third also saw a DMS with the message “Fire in tunnel – walk to exits,” and one-third heard a longer audio message providing similar information and instructions.

Participants who saw or heard a message instructing them to evacuate were much more likely to say they would leave the vehicle and exit on foot compared to participants who received no message: 81 percent of those who received the DMS message said they would leave the vehicle, compared with 73 percent of those who received the audio message, and 20 percent of those who did not receive a message.



Figure 5. Sign formats tested during tunnel simulation

The participants who had not received a message were most likely to request information about the nature and seriousness of the situation and instructions about what they should do. Participants who had received either of the two evacuation messages were most likely to ask about the locations of the exits and how to identify them.

Comprehension of Signs and Markings

Following the in-vehicle portion of the tunnel simulation, participants exited the vehicle and proceeded into an adjacent simulated tunnel to view various signs and pathway markings. The simulated tunnel was illuminated to a horizontal illuminance at the pavement of 10 lux. The chamber was filled with non-toxic artificial smoke prior to the participants entering the tunnel. Participants viewed a total of nine signs, which included six different symbol or symbol-and-text formats (see figure 5); some sign formats were presented using two different technologies (internally LED-illuminated signs and photoluminescent signs).

Three of the signs were symbol-only: a “running man” symbol-only exit sign, a “refuge point” sign, and an emergency telephone sign. Researchers asked participants what they thought each of these signs meant. The other signs all incorporated the word “exit,” and participants were asked where they would expect to find an exit door based on each sign.

Every participant viewed the symbol-only “running man” exit sign first in the sequence; the other signs were presented in one of three different viewing orders. Some additional symbols and sign formats were tested in an exit survey

following the tunnel simulation. Some of the principal results from the sign comprehension testing included the following:

- The stand-alone “running man” symbol was identified correctly by 48 percent of participants as an exit sign. When the 38 percent of participants who said that they indicated a direction or path to follow are included, 86 percent would have been likely to follow this type of sign toward an exit.
- All signs that included the word “EXIT,” whether text-only or text plus a “running man” symbol, were correctly identified by all participants as indicating a tunnel exit or a direction to an exit.
- Most participants thought that the “running man” symbol indicated a direction, even without a supplemental arrow. Therefore, participants most frequently assumed that the “running man” symbol indicated an exit to the side of the sign or further away in the direction that the running figure was facing. However, participants saw the test signs in the context of a wall-mounted frame, and so did not have the added context of a visible doorway.
- A small percentage of participants did not recognize the chevron arrows on an “EXIT” text-only sign as directional arrows. All participants recognized tailed arrows as indicating a direction.
- When the “running man” sign was paired with a (tailed) directional arrow and numbers indicating a distance in feet, comprehension of the exit’s location relative to the sign was correct among 98 percent of participants.
- When a “running man” exit sign included an arrow but no specified distance, many participants assumed that an exit was nearby in the direction of the arrow; if no distance was provided they assumed the distance to the exit was very short.

Participants were presented with four exit path/door marking formats, presented in pairs as follows:

- Steady-state lights vs. lights flashing in unison;
- Unison-flash lights alone vs. unison-flash lights plus an audio beacon in the near distance saying “Exit here.”
- Unison-flash lights vs. “traveling” lights that illuminated in a directional sequence that appeared to move to the participant’s right.
- Unison-flash lights plus an “Exit here” audio beacon vs. “traveling” lights.

In general, flashing lights were preferred to steady-state lights. “Traveling” lights that indicated a direction were preferred as pathway markings to unison-flash lights. The audio beacon was a preferred option to indicate the location of a

doorway. However, several participants indicated that the traveling lights would be more useful for pathway guidance, while the audio beacon would be more helpful close to an exit door.

Sign Luminance, Contrast, and Visibility Distance

Researchers measured the luminance of each sign's positive (brighter) and negative (darker) areas, as well as the gray walls and frames surrounding the signs. Measurements were conducted in clear conditions and through artificial smoke over a range of opacity levels from 4 to 23 percent and in both low ambient light (10 lux) and darkness. The measurements were used to calculate the contrast ratio of each sign compared to the tunnel wall, and also the contrast ratio of each sign's positive and negative elements, i.e., sign legend versus sign background. Sign visibility was also measured by recording the distances at which study participants could detect and read each sign. Some of the signs were internally illuminated by light-emitting diodes (LEDs), while others were PL.

Overall luminance levels and the contrast ratios between signs and the tunnel wall and between the sign legends and background diminished sharply when the signs were viewed through smoke. This significantly affected how far away signs could be seen and also reduced the contrast between their light and dark areas, which made text and symbols more difficult to read. The principal findings from the luminance measurements include the following:

- LED signs had much higher luminance levels than the tested PL signs, but differences decreased as smoke opacity increased.
- Contrast between all signs and wall diminished sharply as smoke opacity increased. When there was ambient light present in the simulated tunnel, the LED signs contrasted more sharply with the wall than did the PL signs; in the absence of ambient light, the PL signs exhibited higher contrast.
- Contrast ratios between sign legends and sign backgrounds were consistently higher for the PL "running man" signs than for the LED versions of these signs. For all signs, contrast ratios of sign legend luminance to sign background luminance diminished as smoke opacities rose.
- The distances at which participants could detect and read each sign were similarly affected by smoke opacity; visibility distances typically dropped up to two-thirds as smoke opacity increased from 5 percent to 20 percent.

Guideline References

- ¹van Waterschoot, A. et al., in Martens, M. (ed), *Human Factors Aspects in Tunnels: Tunnel User Behaviour and Tunnel Operators, Ch 1*. Produced as part of Workpackage 3, Human response D33, UPTUN, September 2008.
- ²Nilsson, D., Johansson, M., and Frantzich, H. Evacuation Experiment in a Road Tunnel: A Study of Human Behavior and Technical Installations, *Fire Safety Journal 44, 2009*, pp.458-468.
- ³NFPA 502: Standard for Road Tunnels, Bridges, and Other Limited Access Highways, 2014 Edition. ISBN 978-145590743-4.
- ⁴ISO 7010: 2011: Graphical Symbols — Safety Colours and Safety Signs — Registered Safety Signs.
- ⁵NFPA 170: Standard for Life Safety and Emergency Signals. ISBN 978-145591089-2.
- ⁶NFPA 101: Life Safety Code, 2015 Edition. ISBN 978-145590942-1.
- ⁷ASTM E2072-14: Standard Specification for Photoluminescent (Phosphorescent) Safety Markings, 2014 Edition.
- ⁸CIE 193:2010: Emergency Lighting in Road Tunnels. ISBN 978 3 901906 91 6.
- ⁹NFPA 72: National Fire Alarm and Signaling Code, 2013 Edition. ISBN 978-145590464-8.
- ¹⁰Mayer, R., Reimann, O., Lover, V., Brettschneider V., and Los, I. (2011). Clear Announcements for Motorists: New Chances for Safe Voice Alarms in Tunnels. Official Journal of STUVA 2/2012. (in German).
- ¹¹The Guardian University Awards Ideas Bank 2014: Winner, University of Greenwich, Project: Active Dynamic Signage Systems. *The Guardian*, U.S. Edition online, February 18, 2014.
- ¹²*Manual on Uniform Traffic Control Devices*, 2009 Edition. Chapter 2L, "Changeable Message Signs," Section 2L.05 "Message Length and Units of Information." <http://mutcd.fhwa.dot.gov/html/2009/part2/part2l.htm>.
- ¹³*Wireless Emergency Alerts (WEA)*, <http://www.fcc.gov/guides/wireless-emergency-alerts-wea>, downloaded October 27, 2015.

PREPARED BY:

Laura Higgins
Paul Carlson
Jeff Miles

Texas A&M Transportation Institute
The Texas A&M University System
College Station, TX

Stephen Rozyckie
Martha Averso
David Graham
Brian Seip

Gannett Fleming, Inc.
Harrisburg, PA

Gunnar Jensen
SINTEF Technology and Society
Trondheim, Norway

The contractor's Final Report is available as
NCHRP Web-Only Document 216 at www.trb.org